

# DRIVE-ON LIFT/TILT TABLES

1,000/2,000/4,000 LBS

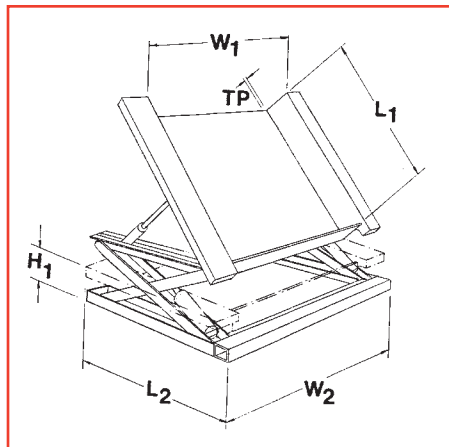
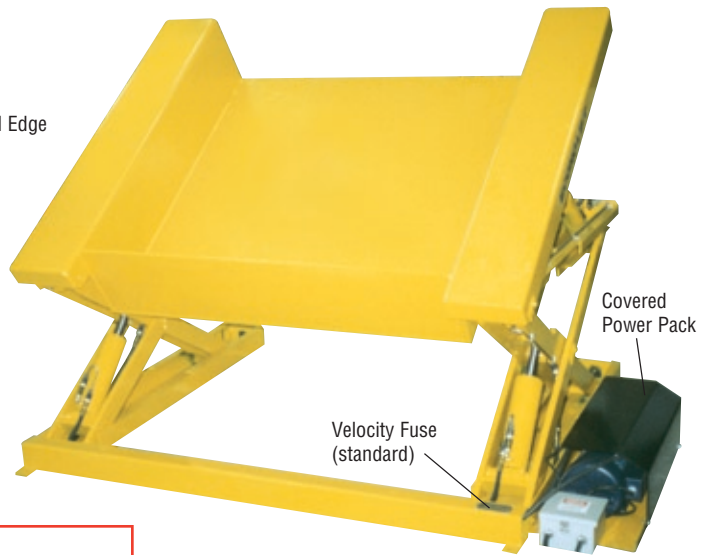
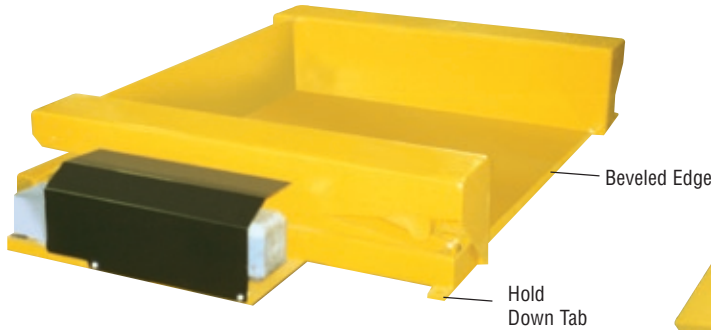

## TRAVEL

- 30", 38"

## TILT ANGLE

- 0-45°

## SAFETY

- Velocity fuse on each cylinder to eliminate tables from collapsing due to hose failure
- Hold down tabs on all four corners

## LOWERED HEIGHT OF TABLE

- Floor level

## POWER SUPPLIES

### A/C 110 volt

Single phase motor  
(hand or foot controls  
standard draws approx.  
15 amps)

### A/C 460/575 volt

Three phase motors  
(optional)

## Air/Hydraulic

Foot operated (Standard)  
(hand held pendant optional)

## OPTIONS

- Different platform sizes
- Bellow safety skirting / safety touch bars
- Vertical travel - high or lower
- Limit switches / photo eyes
- Eye bolts - for moving lifts easily
- Semi Portable - for moving empty lifts, c/w dolly handle

## OPTIONS



Eye Bolt Hole  
(used to move empty lift)

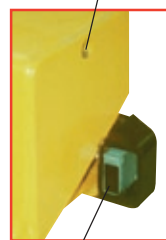

Guarded Safety Photo Eye



MODEL NO.	CAPACITY (LBS.)	PLATFORM SIZE W <sub>1</sub> x L <sub>1</sub> (IN.)	LOW'D HEIGHT TP (IN.)	VERTICAL TRAVEL H <sub>2</sub> (IN.)	OVERALL SIZE W <sub>2</sub> L <sub>2</sub> (IN.)	LOW'D HEIGHT H <sub>1</sub> (IN.)	OVERALL HEIGHT H <sub>3</sub> (IN.)
DO-SL/TRT 30-10	1,000	50 x 50	3/8	30	68.5 x 56	12	42
DO-SL/TRT 30-20	2,000	50 x 50	3/8	30	68.5 x 56	12	42
DO-SL/TRT 30-40	4,000	50 x 50	1/2	30	68.5 x 56	12	42
DO-SL/TRT 38-10	1,000	50 x 60	3/8	38	68.5 x 66	12	50
DO-SL/TRT 38-20	2,000	50 x 60	3/8	38	68.5 x 66	12	50
DO-SL/TRT 38-40	4,000	50 x 60	1/2	38	68.5 x 66	12	50

DRIVE-ONS